



**HOW TO WRITE TECHNICAL
SPECIFICATIONS FOR
DIMENSIONAL GAUGES,
JIGS, CHECKING FIXTURES
AND CMM FIXTURES**

April 2010

INDICE

<u>PRELIMINARY NOTE</u>	<u>3</u>
<u>I. TECHNICAL SPECIFICATIONS - WHY?</u>	<u>4</u>
<u>II. THE CONE OF UNCERTAINTY</u>	<u>5</u>
<u>III. TAILOR-MADE PRODUCTS AND SERVICES</u>	<u>7</u>
3.1 - THE TAILOR	7
3.2 - THE DESIGN OFFICE	7
<u>IV. WHICH ASPECTS ARE INCLUDED IN TECHNICAL SPECIFICATIONS ?</u>	<u>9</u>
4.1 - REFERENCE DOCUMENTS OF EACH CUSTOMER	9
4.2 - CHECKING FIXTURE ALIGNMENT	10
4.3 - PART ALIGNMENT ON THE CHECKING FIXTURE	12
4.4 - PART FIXATION MEANS	13
4.5 - TYPES OF CHECKING SYSTEMS FOR THE DIMENSIONS TO BE CHECKED	15
4.6 - MANUFACTURING MATERIALS	19
4.7 - MANUFACTURING TOLERANCES	20
4.8 - GENERAL IDENTIFICATION OF THE CHECKING FIXTURE AND ITS ELEMENTS	20
4.9 - HANDLING CHECKING FIXTURES	22
4.10 - INFORMATION NECESSARY FOR THE VALIDATION OF THE DESIGN BEFORE MANUFACTURING	23
4.11 - DIMENSIONAL REPORT AND R&R	24
4.12 - USER MANUAL	25
4.13 - PACKAGING AND STORAGE OF THE CHECKING FIXTURES	27
4.14 - MAINTENANCE	27
<u>BIBLIOGRAPHY</u>	<u>28</u>

Preliminary note

This handbook does not pretend to replace the technical specifications currently used by OEMs and their suppliers. It does not pretend either to be a Bible about how to produce dimensional checking fixtures. We have redacted it by using the experiences we have had over the years – as much the good as the bad ones – as well as the variety of projects we have participated to.

The aim of this handbook is to highlight the importance of these technical specifications, which help to reduce the uncertainty in a project and ensure that the further steps will be done within the costs and deadlines planned. It has to be an extra help for companies that have not written yet their technical specifications and wish to write them.

I. Technical Specifications – Why?

The definition of technical specifications for the design of [checking fixtures](#), or jigs, is of paramount importance for companies using frequently these tools. These specifications detail all the features of design, manufacture and storage – as much the general as the specific ones – for each type of product.

Technical specifications are used for the preparation of the quotation for a tooling (RFQ), and as a guideline for its design.

This is why we, at [Tecnomatrix](#), would like to help you to write your own technical specifications, in order to make the task easier for you if you have not done it yet, or to improve them if you have already written them.

The main points technical specifications should include are the following:

- Reference documents for each of your customers.
- Checking fixture alignment.
- Part alignment methods.
- Part fixation methods.
- Systems and types of controls of the dimensions to be checked.
- Manufacturing materials.
- Manufacturing tolerances.
- General identification of the checking fixture and its elements.
- Information necessary for the approval of the design before manufacturing.
- Dimensional report and R&R.
- User manual.
- Packaging and storage of the checking elements.
- Maintenance.

These data are defined depending on the type of part to be checked and its level of precision. Do not forget that an excess, or a lack of quality trigger a loss of competitiveness. This means that, as a general rule, you should not have the same specifications for metal parts as for injected or puffed plastic parts, for example.

If you do not know when you should use checking fixtures, or how often, you can take as a reference the Military Standard 105 ([MIL-STD-105](#)), that details the procedures and tables to do a sampling for a correct inspection of your production.

II. The Cone of Uncertainty

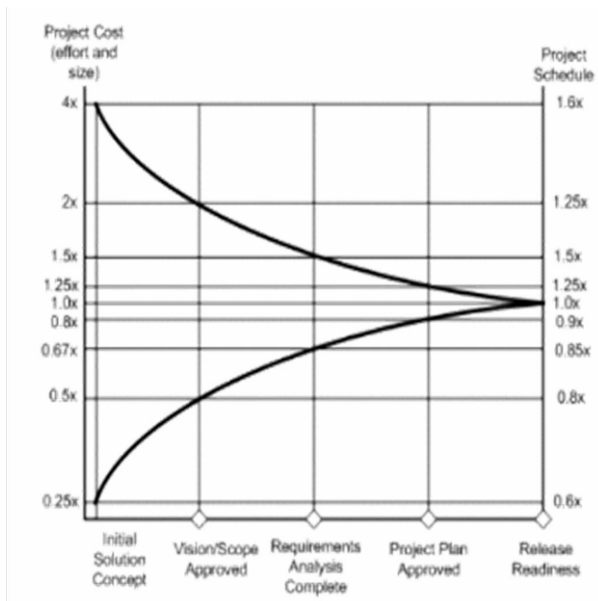

Generally, a “project” is defined as a *time-limited effort to reach a goal*. The **cone of uncertainty** is the tool we use, consciously or unconsciously, to **estimate the costs and deadlines to carry out a project**. Depending on how precisely the project steps are defined, you will have a repercussion on the cost and deadline estimations. That way, you will get estimated costs ranging from 0.25x to 4x, “x” being the actual final cost that you will only know for sure once the project is over.

In practice, if we have to prepare a quotation for checking fixtures, there will be a huge difference, as far as risk is concerned, if we have some comprehensive and detailed technical specifications or if, on the contrary, we do not have enough information about what has to be checked, how to fasten the part, or if the part has to be checked by attributes or variables. Saying “you are the expert” does not give any information and only helps to confuse your supplier. An accurate quotation requires precise information, 3D files of the part and its environment, and 2D plans correctly made – indicating the critical characteristics that have to be checked -.

The definition of a checking fixture will have important consequences on:

- The design and creation of the 2D and 3D of the project.
- The materials to be used, the elements of metrology to be included and the surface and heat treatments.
- The manufacture of every element of the checking fixture.
- The adjusting, depending on the tolerances and requests.
- The subsequent works, such as R&R studies, user manuals, parts dimensional reports, and so on.

Uncertainty does not benefit to any of the two parties and only transfers the risk from one party (customer) to the other (checking fixture manufacturer). A project lasting or costing more than what was planned will only cause damage to the party taking the risk. When one loses, both parties lose because if the customer wanted to receive his order on a determined date and unforeseen events delay the delivery and increase costs, the situation will begin to snowball without bringing any value.

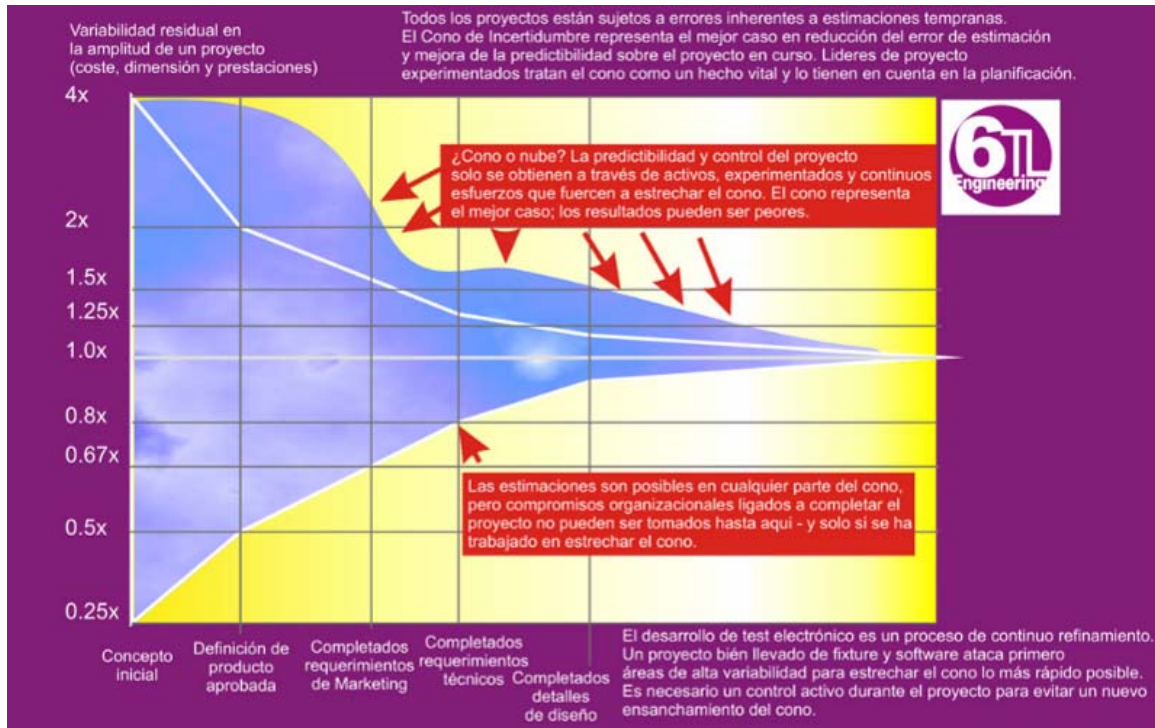

Sources: <http://www.6tl.es/sabermas.asp>
<http://www.construx.com/Page.aspx?hid=1648>

III. Tailor-Made Products and Services



Did you know that when purchasing either [checking fixtures](#) or tailor-made suits the consumer behaviour is quite similar?

Actually, the similarity is in the fact that both products are **tailor-made**, and the professional needs to be given some key indications, in order to give us exactly what we need.

3.1 - THE TAILOR

If you wish to get a nice suit, and do not have the body of a model so that any suit will fit you perfectly, you will have to go and see the tailor. The tailor will take your measurements and will then ask you:

- What you want this suit for: if it is for a special day, if it is to go to work, and so on.
- Which fabric and colours you prefer.
- Which season of the year you need it for.
- Which style you want for the jacket, for the sleeves buttons and the trousers hems.

Afterwards, he will have to adjust your suit when you come to try it on, even if he had previously taken your measurements.

Nobody would go to a tailor and order a suit size 42 without any other indication. And answer, when the tailor asks for our preferences: *"you are the specialist, aren't you?"*

3.2 - THE DESIGN OFFICE

This is the same for checking fixtures. We need to have a [3D geometry](#) of the part and a 2D drawing with the dimensions and tolerances, but this is only the information to get started.

We also need to have some technical specifications, or more simply a series of indications to create the perfect design. It is important to know:

- Which materials the customer prefers to work with
- Which dimensions have to be checked
- Which reference points (RPS) our customer wishes to use (if they are not specified in the drawing)

- Which type of checking methods the person that will check the parts prefer to use
- What is the budget available for this project

Customers, however, are not always aware of the fact that these answers are important. And they do not realise either that the final result depends basically of the interest they will put in answering these questions.

In the case of rather complex checking fixtures, we have seen that if the engineer in charge of the project in our customer's plant does not get involved thoroughly in the design of the checking fixture, it will usually end up being unused or – if it is indeed used – it will not give an optimum result.

It is important to foresee all the potential problems and to finally have a part sample to make final adjustings of the checking fixture and of the fixation elements. If we have part samples, we will be able to study the repeatability of the fixture – without them, it will be impossible.

IV. Which Aspects are Included in Technical Specifications ?

4.1 - REFERENCE DOCUMENTS OF EACH CUSTOMER

Within this section, you will have to take into account the information provided by the final customer. Depending on each **OEM**, you will only receive general technical specifications (to be used for all the checking fixtures) or you will even be provided with specific technical specifications for each and every particular checking fixture. The latter are usually redacted by TIER1s under the supervision of OEMs.

PLIEGO DE CONDICIONES PARA MEDIOS DE CONTROL EN PIEZAS DE COMPRA

PRODUCT SPECIFICATIONS
RENAULT
VERIFICATION DEVICES FOR BODY EQUIPMENT PARTS

CAHIER DES CHARGES DES MOYENS DE CONTROLE DES PIECES EMBOUTISSAGE

MEZZI DI CONTROLLO
INDICE RIPILOGATIVO PER CATEGORIA GRUPPO E NUMERO DA 4.00.01 A 4.05.50

C	D	H	A	R	U	M	ARGOMENTO	P	E	D	NOTE
-	-	-	-	-	-	-		A	G	A	
-	-	-	-	-	-	-		Z	I	T	
-	-	-	-	-	-	-		-	-	-	
4	00	01					Premessa generale	1	1	31-10-97	
		02					Guida all'interpretazione della metodologia	1	1	31-10-97	
		04					Critica generale per la progettazione	3	1	31-10-97	
							FIGURA IN RESINA CON INCASTELLATURA IN MONOLOCCO FUSIONE ALLUMINIO.				
		05					Prescrizione per la progettazione e costruzione	4	1	31-10-97	
		02					Asserimenti su base	6	1	31-10-97	
							FIGURA ED INCASTELLATURA IN MONOLOCCO FUSIONE LEGA D'ALLUMINIO				
		15					Prescrizione per la progettazione e costruzione	1	1	31-10-97	
							FIGURA IN RESINA O IN LEGA D'ALLUMINIO DIRETTAMENTE FISSATA SU PIASTRA DI BASE				
		20					Prescrizione per la progettazione e costruzione	1	1	31-10-97	
							NORME/PRESCRIZIONI COMUNI PER PROGETTAZIONE, COSTRUZIONE E VERIFICA				
		00					Guida al controllo del progetto	1	1	31-10-97	
		21					Prescrizioni per la costruzione fuori figura tessili per controllo grafici continui	1	1	31-10-97	
		22					Prassi di riferimento / controllo superficiale in accoppiamento	7	1	31-10-97	
		23					Rilasciamenti - Posizionamenti	8	1	31-10-97	
		25					Modelli in resina	1	1	31-10-97	
		26					Punti SPC e punti di controllo comuni	2	1	31-10-97	
		27					Controllo tipo	3	1	31-10-97	
		28					Controllo a dima rotante tipo "A"	2	1	31-10-97	
		29					Controllo a dima rotante tipo "B/C"	4	1	31-10-97	
		30					Controllo a dima tipo "C"	2	1	31-10-97	
		31					Prassi di posizionamento per dima	1	1	31-10-97	
		32					Controllo a lampone PIP	1	1	31-10-97	
		34					Terghetta vana	2	1	31-10-97	
		35					Colorazioni	5	1	31-10-97	
		40					Guida alla compilazione e diffusione della check list	4	1	31-10-97	
		50					INDICAZIONE SPECIFICHE M.C.C. ELEMENTI BUY	1	1	31-10-97	

If the final customer requires the use of determined checking patterns, they will have to be taken into account to define the design of the **checking fixture**. A pattern requiring to check the parts very often will mean that you will have to implement a user-friendly and quick checking system, in order to avoid increasing the related costs.

The specific technical specifications will detail what type of gauging system is required for the verification of a given part, depending on the indications provided by the final customer: the part will have to be checked in the production chain, in the metrology laboratory, etc.

In some occasions, the final customer can also provide a list of critical points he wishes to check: these points will also have to be taken into account.



CMM fixture for dashboard



Checking fixture for plastic ribs

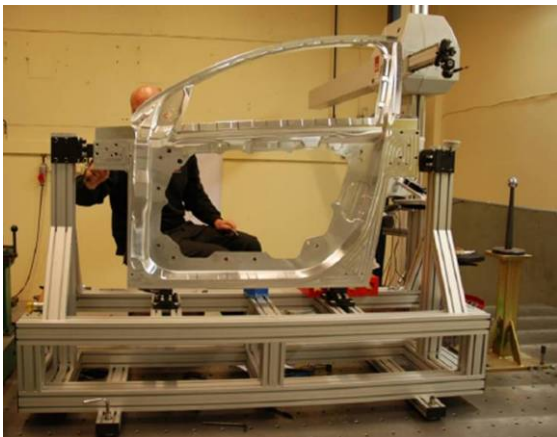

CMM fixture for door frame



Meisterbock for body-in-white



Go/No Go gauges

4.2 - CHECKING FIXTURE ALIGNMENT

In order to carry out periodical verifications on your [checking fixtures](#), it is important to have references enabling you to position the fixture in a coordinates system. This alignment can be geometric or by 3 centres.

The alignment can be done by:

- Machined planes on the base plate
- Part aligning elements (RPS)
- Sights or spheres driven into the base plate
- Rectified steel bushings driven into the base plate

The geometric alignment system is more precise, and is probably the best one on a metrological point of view; yet, it is also the most complex and expensive system, since it aligns the checking fixture by using the same areas as the ones used to align the part to be measured.

The most commonly used system is the one using three rectified bushings, as it enables to get a precision very close to theory with more reasonable costs.



Machined planes

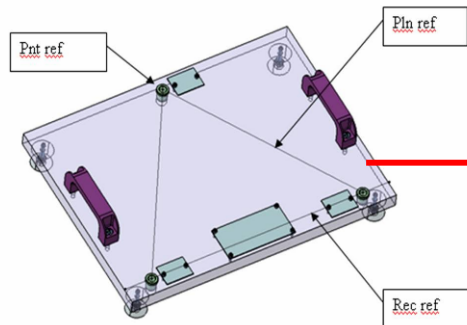

Alignment by three centres

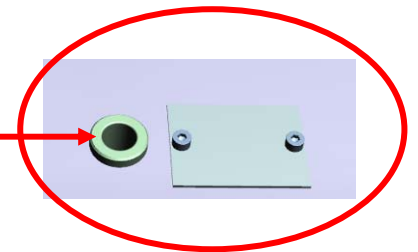

Reference bushing. Also enables to adapt a sight



Sights

Even if you have already chosen your alignment system, you can also have your checking fixture designed to be used in different positions in order to make its use easier. The position of some of the parts of a vehicle do not allow to check them in a comfortable way; in those cases, it can be very interesting to have a fixture enabling to be positioned according to one, or several axes. Consequently, this section of your technical specifications will have to determine whether the use of inclined structures will be necessary, or not.

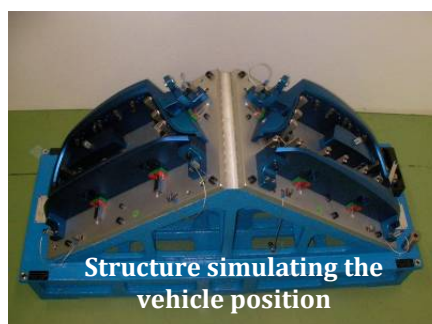

Structure simulating the vehicle position

4.3 – PART ALIGNMENT ON THE CHECKING FIXTURE

The part RPS, indicated in the 2D drawing, are usually used to align the part.

Remember to identify clearly the location of the RPS, and how you want to simulate them. The fixations are usually an accurate reproduction of the real environment of the part, but it is also possible to represent only the theoretical RPS.

The cost of each system can be quite different, and so are the measurement results each system can provide; consequently, it is very important to define them from the beginning.

The part alignment system must prevent the part from being mounted in different positions on the checking fixture; this can be done by using **conic and retractable** centring elements, that can absorb the tolerances of the elements used to centre the part. This is the only way to ensure the checking fixture repeatability for measurements, and good results in the **R&R studies**.

In many cases, the [checking fixture](#) will be used to carry out as much checks in the production chain as in the metrology laboratory. If the checking fixtures are to be used to do measurements with a CMM machine, you have to say so, in order to design the alignment systems in a way allowing the access of the CMM machine probe.

In some cases, a preliminary control of the element enabling to align the part may be required – for example, if you align your part on a hole, you may need to check previously the hole with a Go/No Go pin -. The alignment of the part, however, should always be done on surfaces regarded as reliable, that is, with no tendency to get deformed during the part production process.

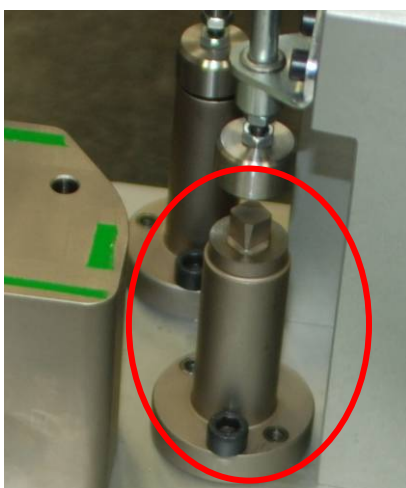

Diamond-shaped centring pin, enabling to center the part in one direction.



Conic centring pin, enabling to center the part on one of its holes; the shape of the centring pin allows to absorb the hole manufacturing tolerance to center the part in a optimum way.

In cases like the one displayed bellow, the vehicle fixation system will be represented by pins or openable clips.

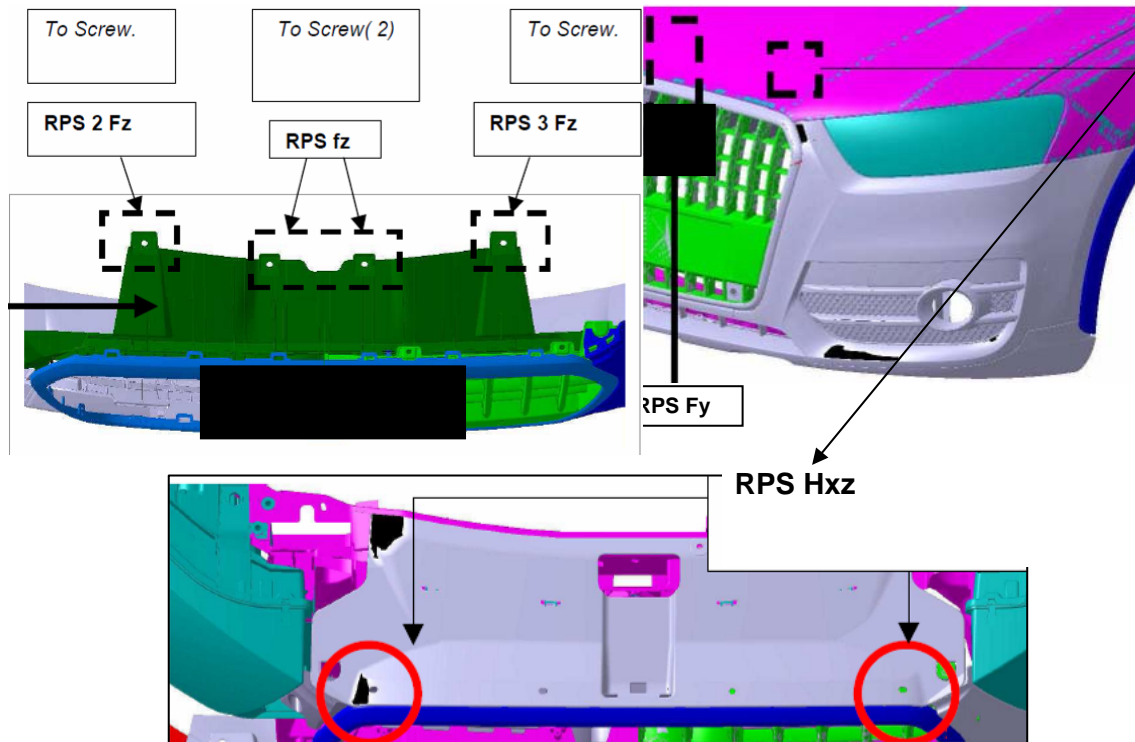

4.4 – PART FIXATION MEANS

Once the part is aligned, it has to be fastened on the checking fixture to prevent it from moving. It is essential to make sure that the fixation systems block the part to measure, but do not deform it by fastening it too tightly.

To fasten the part, you can use manual or pneumatic clamps, screws simulating the vehicle fixation, magnets, clips simulations, fixed blocks representing the part environment, etc. Each part will have to be studied depending on its materials, environment and areas to be checked. Depending on the cases, the fixation systems and holding points may be/must be retractable, in order to make the mounting and check of the part easier.

Sometimes, customers request a fixation of the part through perpendicular fastening clamps, that is, with a rotation point aligned with the part plane. Such a clamp ensures that the part will not move when putting the clamp down; this type of clamp can be used without any problem, but as it is a special system it is essential to request it in your technical specifications, since it implies an extra cost.

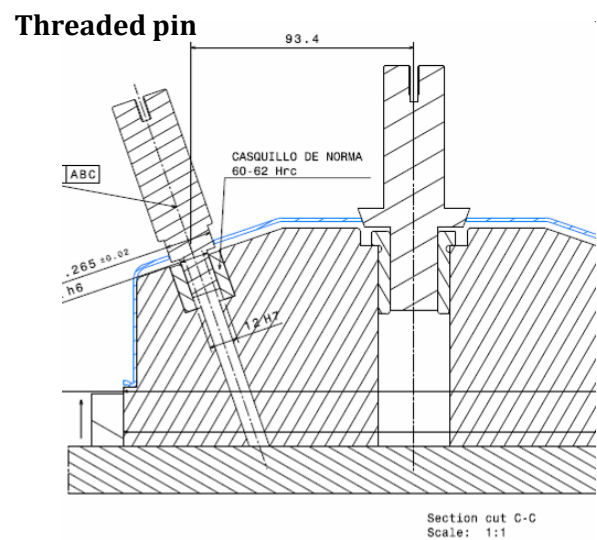
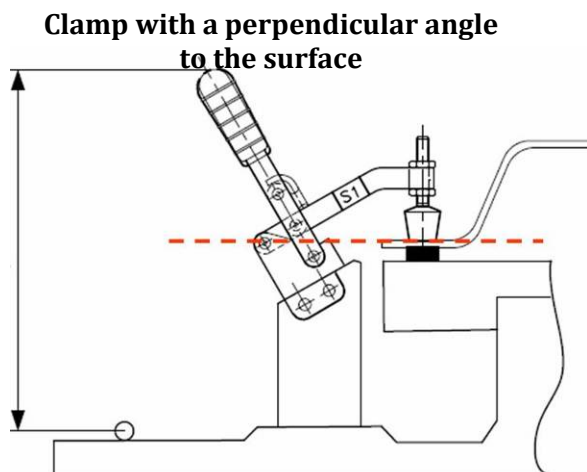
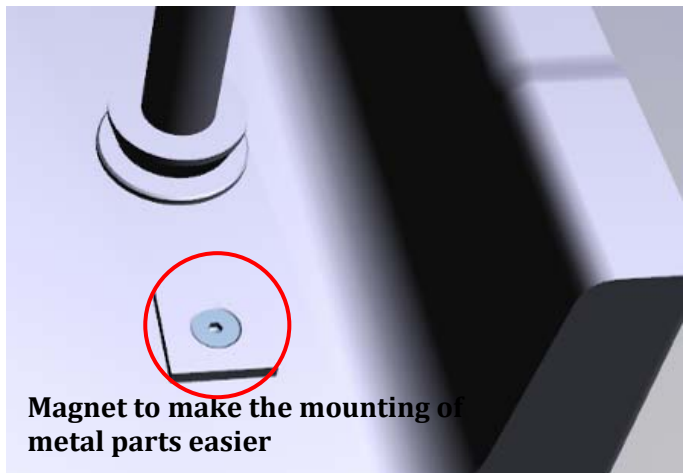
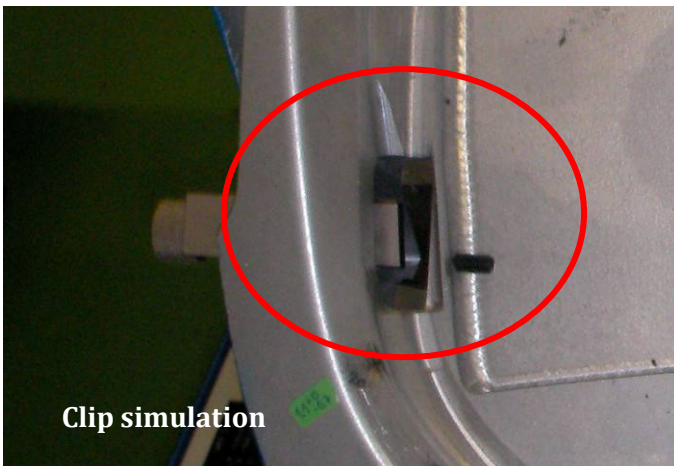
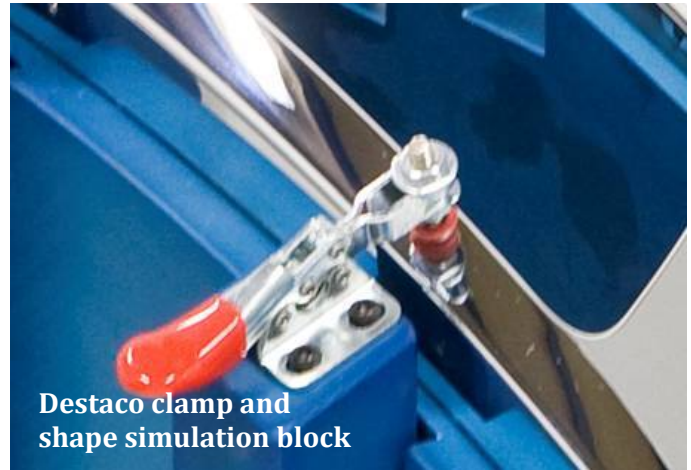

4.5 - TYPES OF GAUGING SYSTEMS FOR THE DIMENSIONS TO BE CHECKED

It is important to carry out a [FMEA](#) (Failure Mode and Effect Analysis) to detect all the possible problems you will have during the fabrication and mounting of the part, or assembly of parts, you want to check. Thanks to this analysis, you will find the part critical points and be able to study the best way to check them, as well as to foresee the possible mountability problems of your assembly of parts on the vehicle. To do this [FMEA](#), you can get based, if you have it, on the [Moldflow](#) analysis – for plastic parts – or in the [FEA stamping simulation analysis](#) – for metal parts -.

An excessive number of checking points will require a more complex design, increasing thus the [checking fixture](#) manufacturing costs. A checking fixture without any points to check, which only aim is to help positioning the part, is called a “Positioner”, and it is usually used to align the parts quickly to measure them by CMM machine. This system is particularly useful for parts tending to have a high plastic deformation, and that need to be conformed before being measured.



Your general technical specifications will have to define the different types of checking systems that your final customer regard as necessary for a full control of the part, as well as their corresponding characteristics; generally, the general specifications talk about:

- [Go/No Go gauges](#): gauges made of a handle and two measuring elements, where one measuring element corresponds to the maximum value of the dimension to measure (No Go), and the other measuring element corresponds to the minimum value of the dimension to measure (Go). The Go/No Go gauges belong to the category of attributes control means, and are used to verify diameter, special shapes as well as gap and flush areas.

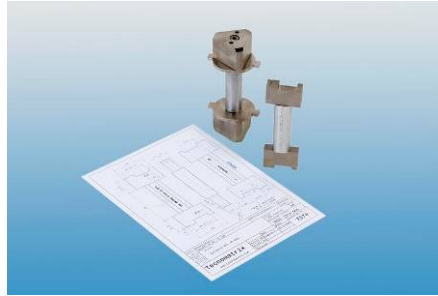

- **checking fixtures:** mechanical assembly for the dimensional verification of mass-production parts, with the aim of doing the same repetitive checks on parts assemblies that have been aligned in exactly the same way, regardless of the person doing the measurements. They are frequently used in industrial sectors, such as the automotive, domestic electrical appliances industry, aircraft, pharmaceutical - ... - by parts and components manufacturers. They are also called jigs or gauges and are designed to check a determined part.



- **cuttings:** mechanical assembly simulating the vehicle mountability conditions. It is made of a simulation of the part fixation system, as well as blocks reproducing the environment of the part to check.



- **CMM fixtures** (also called positioners): structure enabling to position the part on a CMM machine by aligning it by its RPS. Contrary to a checking fixture – which also positions the part in the same way – the CMM fixture does not have any type of checking element giving information about the part; it only enables the probe of the CMM machine to access easily to the areas that have to be measured.

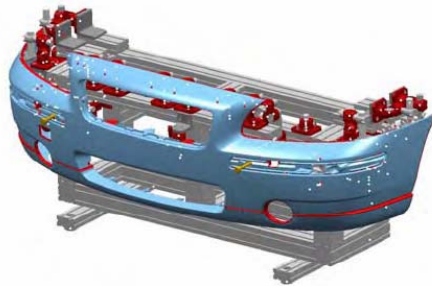

- **Hybrid checking fixture/CMM fixture:** checking fixture adapted to carry out measurements by 3D machine. The checking fixture will have removable or sliding areas allowing the access to the 3D machine probe. This type of checking system is particularly used by companies needing to check parts in production (conformity of the parts) as well as in metrology laboratory (measurement of parts for SPC), but do not wish to have two separate checking fixtures.

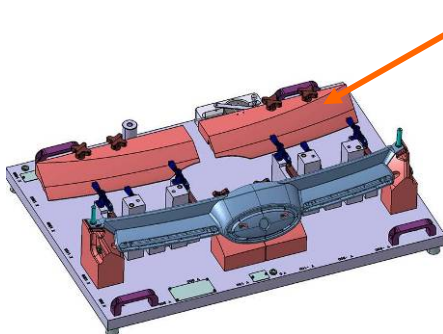

The fixture positions the part for CMM measurements

Once the removable blocks have been adapted on the upper parts, the fixture enables to check the part: it is now a checking fixture

- **Hybrid checking fixture/cubing:** checking system enabling not only to verify the critical areas of the part (checking fixture), to improve the production process, but also to simulate the part real mountability conditions (cubing) in order to prevent possible mountability problems in the final assembly. To do so, the part environment simulation blocks can be removed, enabling to switch from a checking fixture to a cubing.

Removable
simulation block

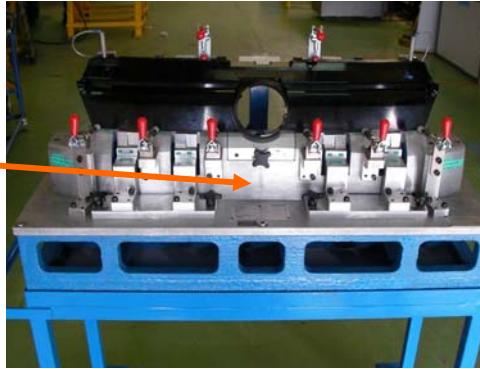

- **automated checking fixtures:** mechanical-pneumatic system to check the dimensions of a part; its aim is the same as a regular checking fixture, but it checks the part thanks to probes and measuring sensors or attributes recording the measured data in a PC, for further processing. They enable to save costs for data collection and to increase the reliability of the measurements obtained by eliminating the mistakes due to a bad transcription or other human-related factors.

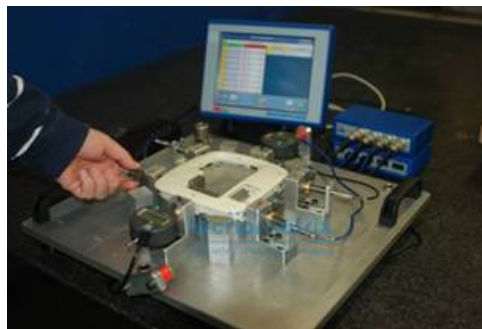

The points or features to verify can be checked in two ways:

- By attributes, such as Go/No Go gauges (you will only know if the part is OK or NOK)
- By variables, such as dial indicators, dynamometers, torque wrenches or measurement probes (you get a determined value every time you measure)

Checks by variables are particularly indicated to carry out capacity studies directly with your checking fixture, and to do a follow-up of the part production. The results will enable you to do a preventive follow-up and to avoid non-conformity problems by taking relevant decisions.

To define which type of checking methods should be used on your checking fixture, it is essential to take into account the experiences you have had with each of the checking methods available. The preferences of the staff qualified for this type of work can vary a lot, and they must be taken into account to make sure that the chosen solution will suit them. Should you chose a system that may not be convenient for the people in charge of checking the parts, it will quickly stop to be used. What is more, in the case of checks by variables, you will also have to determine which feature should be the main one on your checking fixture, that is, if it is more important for it to be quick, to be able to process measurement data, or

to be user-friendly. Once you have defined these features, you will be able to determine which variable measuring instrument is adapted to the checking fixture to produce.

Depending on the physical characteristic (distance, pressure, torque), you will chose the most suitable system (linear ruler, torque wrench, etc.)

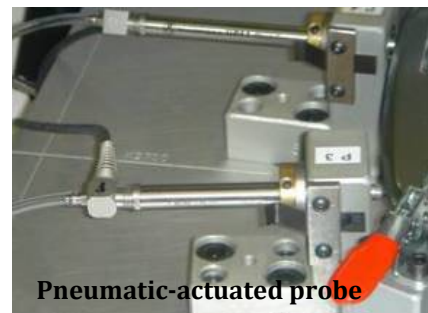
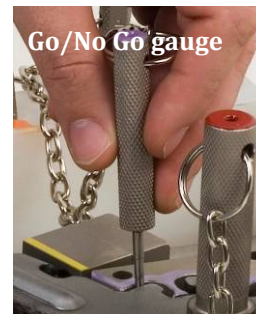

4.6 – MANUFACTURING MATERIALS

Most of the time, the materials we use are aluminiums or steels chosen according to the material of the part to be checked, and to how often the part is to be checked. In some particular cases, the use of aluminium-loaded resins or technical plastics may be required, even though they are less and less used due to their relative fragility for a use in a production chain.

To protect the parts from environmental or production-related tear-and-wear, we recommend to use heat and surface treatments. As for aluminiums, we recommend to apply hard-anodizing; for steel elements, we use chemical nickel.

In spite of the extra cost the tempering of parts means, we recommend to always submit the parts of your checking fixture to heat treatments. Heat treatments enable to get a harder checking fixture, which will guarantee it a longer useful life, a higher repeatability, and consequently a quicker repayment of your investment.

It is essential to have the elements most submitted to tear-and-wear, such as RPS, produced in tempered steel to make sure that they will not wear on during the useful life of your checking fixture.

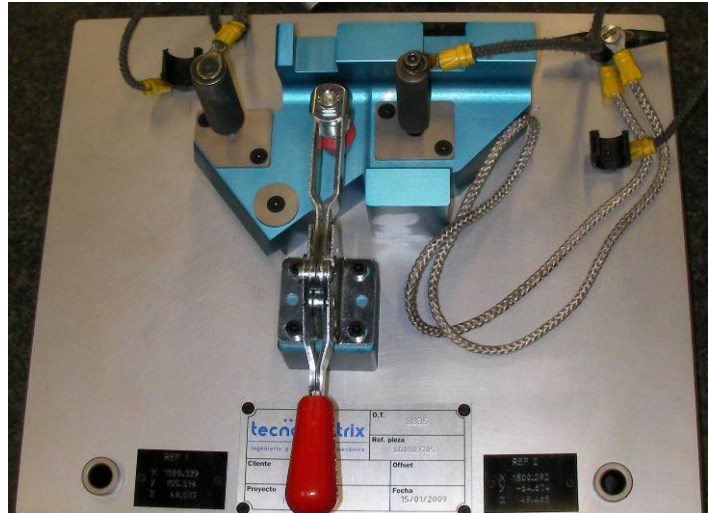

Choosing well the most suitable material for the production of your checking fixture is crucial. The material will be chosen depending on the type of part to check (plastic/metal) and to the hardness of the material, as well as on the checking frequency. A wrong choice can end up in the result you can see on the picture above, on the left: in this case, the checking fixture was produced in resin to check a metal part. The resin wore on, the angles got rounded, and the gap and flush checking areas were lost.

The only solution available to this problem was to produce a new checking fixture with the right materials, as you can see on the picture on the right side: the right material was hard-anodized aluminium, with tempered-steel centring elements.

4.7 - MANUFACTURING TOLERANCES

Manufacturing tolerances will be specified in your general technical specifications, and they will have to be specified as well, or adjusted – if the part features make it necessary – , in your specific technical specifications. You will have to define the manufacturing tolerances for the reference points (RPS) of the points to be checked by attributes, and of the points to be checked by variables. Depending on the cases, technical specifications can specify that the referencing and checking tolerances will have to account for X% of the part manufacturing tolerances (usually, 10%); or, you can also make a list of the manufacturing tolerances corresponding to each dimension to be checked.

4.8 - GENERAL IDENTIFICATION OF THE CHECKING FIXTURE AND ITS ELEMENTS

To identify the elements of your [checking fixtures](#), you may use identification plates, carved elements, colour codes and/or stickers.

Colour codes vary depending on:

- Who is the final customer; he is the one who will define the RAL for his projects in his general technical specifications (Eg: yellow for PSA, red for SEAT,

etc.). Usually, the colour identification is made by painting the edges of the checking fixture base plate.

- The project reference
- The number of controls to do: if your [checking fixture](#) includes many controls, in particular with Go/No Go gauges, you should identify each checking area and its corresponding Go/No Go gauge with a colour code. In this case, the identification will help identifying the different elements available on the checking fixture. This option should also be used if your checking fixture has many removable elements.
- The Go and No Go sides of the Go/No Go gauges: the international standard in this case is green for the Go side, and red for the No Go side.

Depending on the requirements of the project specified either in your customer's general or specific technical specifications, these colour codes can be complemented by **stickers** identifying key elements of the checking fixture such as: RPS, removable blocks, etc.

Finally, the [checking fixture](#) removable elements are **carved** to make the identification of their characteristics easier. For example, in the case of Go/No Go gauges, the Go and No Go diameters will be carved.



Example of a painted and carved Go/No Go gauge, with the identification of the Go (P) and No Go (NP) sides, or their corresponding diameters, as well as the corresponding control code (identification chosen by the customer)

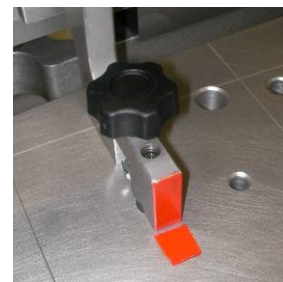

Paint identification of a removable element and its corresponding location on the base plate.



Identification of the base plate edges with a colour code



Stickers identifying the checking fixture RPS (foreground) as well as a removable block (background)

The identification plates help you see easily the project reference corresponding to each of your [checking fixtures](#).

They usually display:

- The name of the checking fixture manufacturer direct customer
- The name of the final customer
- The project reference
- The name of the part, if it is a single part, or if there is one left and one right part
- The date of end of manufacture of the checking fixture

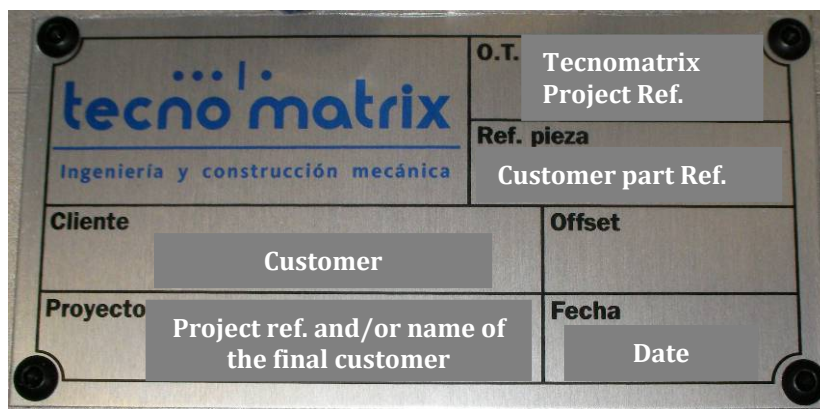

4.9 – HANDLING CHECKING FIXTURES

Depending on the [checking fixture](#) size and weight, it will also be important to consider the use of elements helping the users to handle the checking fixture easily and safely. The technical specifications must specify the elements necessary for this handling, such as:

- handles: they are usually used for a handling of the checking fixture by the control operator. Consequently, they are more adapted to relatively small [checking fixtures](#) (weighing less than 50kg). The handles are usually located at each extremity of the checking fixture.

- rings: their aim is to handle the checking fixture with some kind of handling equipment (forklifts, overhead cranes, etc.) They are thus commonly used for checking fixtures which size or weight does not allow a handling by operators. It can also be required if the part checking will be done by one single operator, in order to avoid any risk of falls during the handling. The technical specifications will have to indicate the distance of positioning of the rings, as well as any piece of information the checking fixture manufacturer should know when mounting the rings on the fixture.

- openings for forklifts: recommended for the handling of [checking fixtures](#) with an aluminium founding basis. In that case, the distance between each fork will have to be specified, in order to leave enough space for each fork in the founding basis.

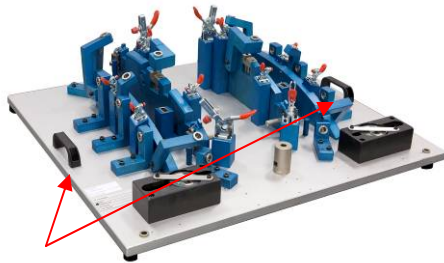

Checking fixtures with handles



Checking fixture with handling rings



Aluminium founding basis suitable for forklift handling

4.10 – INFORMATION NECESSARY FOR THE VALIDATION OF THE DESIGN BEFORE MANUFACTURING

Every checking fixture manufacturer has his own production process. At Tecnomatrix, we know that the best way to make sure that the checking fixture we are going to manufacture meets our customer's requirements is to send them a 2D and 3D of the fixture design before beginning to manufacture. And no matter how urgent a project is, we never start to manufacture any of our checking fixtures without having received its written validation from our customers. The plans help the customer determine if all the elements requested in the technical specifications have been taken into account in the design, as much the fixations as the checking elements. Here is an example:

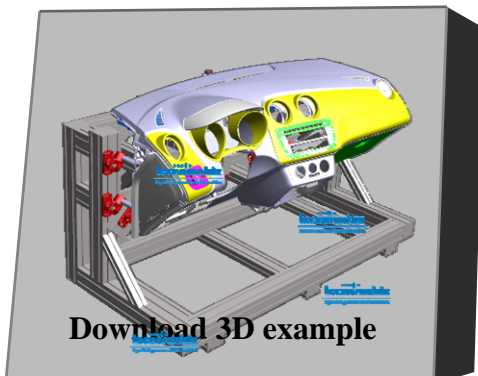

Your checking fixture manufacturer must have a system enabling to get traceability in your projects, because in many occasions projects are subject to modifications:

- Of the part plans, which will affect the design of the checking fixture
- Of the customer project management team, as people will be added or removed from the team
- Of the final customer control requirements

etc.

In such conditions, a human error can happen very quickly without a good management system. This is why Tecnomatrix has developed its own project management portal, called [TecnoNet](#), to manage the project with a good traceability, transparency and control: we use this portal to communicate with our customers, send and receive all the project-related documentation – be it the part plan or the checking fixture design – and do the project planning. Thanks to TecnoNet, we and our customers can use information classified by chronological order, and displaying the actions of each and every participant to the project. One of the main advantages of this portal is the fact that every time a participant to a project adds or modifies an element, the rest of participants receive an automatic email notification, making thus sure that there is a constant transmission of information, and that misunderstandings or losses of information will be avoided.

4.11 – DIMENSIONAL REPORT AND R&R

The [dimensional report](#) is the document created once the [checking fixture](#) has been measured in order to check that all the checking elements and RPS were manufactured according to the tolerances required by the customer. It is delivered with the checking fixture, and lists all the points measured, as well as the deviations detected between the [checking fixture](#) design and the real checking fixture. A checking fixture can only be regarded as conform and operational if all its elements are within the tolerances requested by the customer.

The section dedicated to **dimensional reports** will detail:

- The elements that are to be included in the [dimensional report](#): part alignment elements, surfaces of the checking elements of the checking fixture...
- The reference for the measurement of the checking fixture: according to the part geometry or to the checking fixture geometry
- Type of alignment: by three centres, or geometric

Download an example of dimensional report

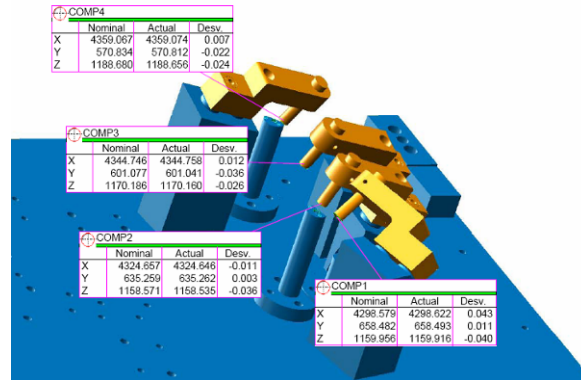

If the final customer requests it, you will have to carry out a **capability study and a R&R study (repeatability and reproducibility)**. These studies can be made either by the TIER1, or by its supplier of checking fixtures, but it must be clear that both of them must take on the responsibility of this study and that should the report not give a satisfactory result, the problem will have to be solved by the two of them. The problem may come from a non-conformity of the checking fixture or from alignment problems of the parts. The technical specifications will have to define who will be in charge of doing these studies, as well as:

- The measurement method: the [R&R](#) can be done by using the variable checking elements (dial indicator, torque wrench, etc.) or by touching an identical series of parts by CMM machine. The latter option takes more time, and will be used more particularly if the checking fixture does not have any variable checking elements.
 - The standard to do the study (for example, the [CNOMO](#) standard for Renault and PSA projects) or the [MSA 3th edition](#)
 - How many parts are to be measured
 - How many times each part has to be measured
 - How many operators are to participate to the study

Example: *The R&R study will be done by dial indicator with 10 parts mounted 3 times by 3 different operators.*

4.12 – USER MANUAL

The user manual is optional; as such, the specific technical specifications will have to say whether or not it is required for each checking fixture.

The main function of the user manual is to give explanations about how the checking fixture works, as well as recommendations for its maintenance.

The user manual must be, above all, simple and quick to read and to understand. It will have to be suitable to be used either by a production chain operator (who will not have many time to check his parts) or by a laboratory technician specialised in this work (who can dedicate more time to this job).

Even though several configurations are possible, we recommend to include at least in the user manual:

- A general view of the checking fixture, with a description of the function of each of its elements
- Recommendations to guarantee a longer useful life to the checking fixture (cleaning, storage, use in production chains, etc.)
- An illustrated section explaining how to mount and fasten the part on the checking fixture
- The list of each checking element and how it works, with pictures and simple and clear description.



**Download an example
of user manual**

4.13 - PACKAGING AND STORAGE OF THE CHECKING FIXTURES

Checking fixtures are precision tools, and must be treated with the corresponding respect and care.

To ship them, we recommend to pack them in a tailor-made wooden box, and to tie and wrap securely the mobile elements (Go/No Go gauges, removable blocks) to the base plate.

Here are other options to pack a checking fixture: a plastic box or a pallet (not recommended due to the risks of blows).

When the checking fixture is not used, we recommend to store it in its box, to avoid any risk of damage, falls of elements, and to keep the checking fixture clean and ready to use.



4.14 - MAINTENANCE

To ensure a longer useful life to the checking fixture, as well as a good quality and precision throughout time, it is advisable to carry out maintenance operations on checking fixtures; a calibration, for example, is very important to re-adjust all the fixation and checking elements of the checking fixture, and thus make sure that it will continue to check parts with the same level of reliability.

Cleaning frequently the checking fixture will also help to make sure that the RPS and checking elements are still precise and user-friendly. It is also important to check that no element is rusting.

Keeping your checking fixtures clean and in a good state will help you to be sure that you are checking your parts more quickly and with more reliability, and will also give a good image of your checking methods to your customers.

BIBLIOGRAPHY

- Documentation from Tecnomatrix Design Office, www.tecnomatrix.com, March 2010
- **Measure Control Blog**, www.measurecontrol.com, March 2010
- **Wikipedia**, <http://en.wikipedia.org/>, March 2010
- **6TL Engineering**, <http://www.6tl.es/index.asp>, March 2010
- **Construx**, <http://www.construx.com/>, March 2010
- **Fundibeq**, <http://www.fundibeq.org/>, March 2010
- **CNOMO**, <http://www.cnomo.com/>, March 2010
- **Scribd**, <http://www.scribd.com/>, March 2010

This manual has been created by **Tecnomatrix** and its authors **Xavier Conesa** and **Gladys Becerra**. Thank you for distributing this e-book to everyone who may be interested in it, without modifying, copying or selling it.

- 1st edition of the manual: March 2010
- 2nd edition of the manual: April 2010